

LOC		DIST		REVISIONS			
P	LTR	DESCRIPTION	DATE	DWN	APVD	REV	REV
A	REV PER EC	OS11-0201-04	14JUN2005	AF	SF		

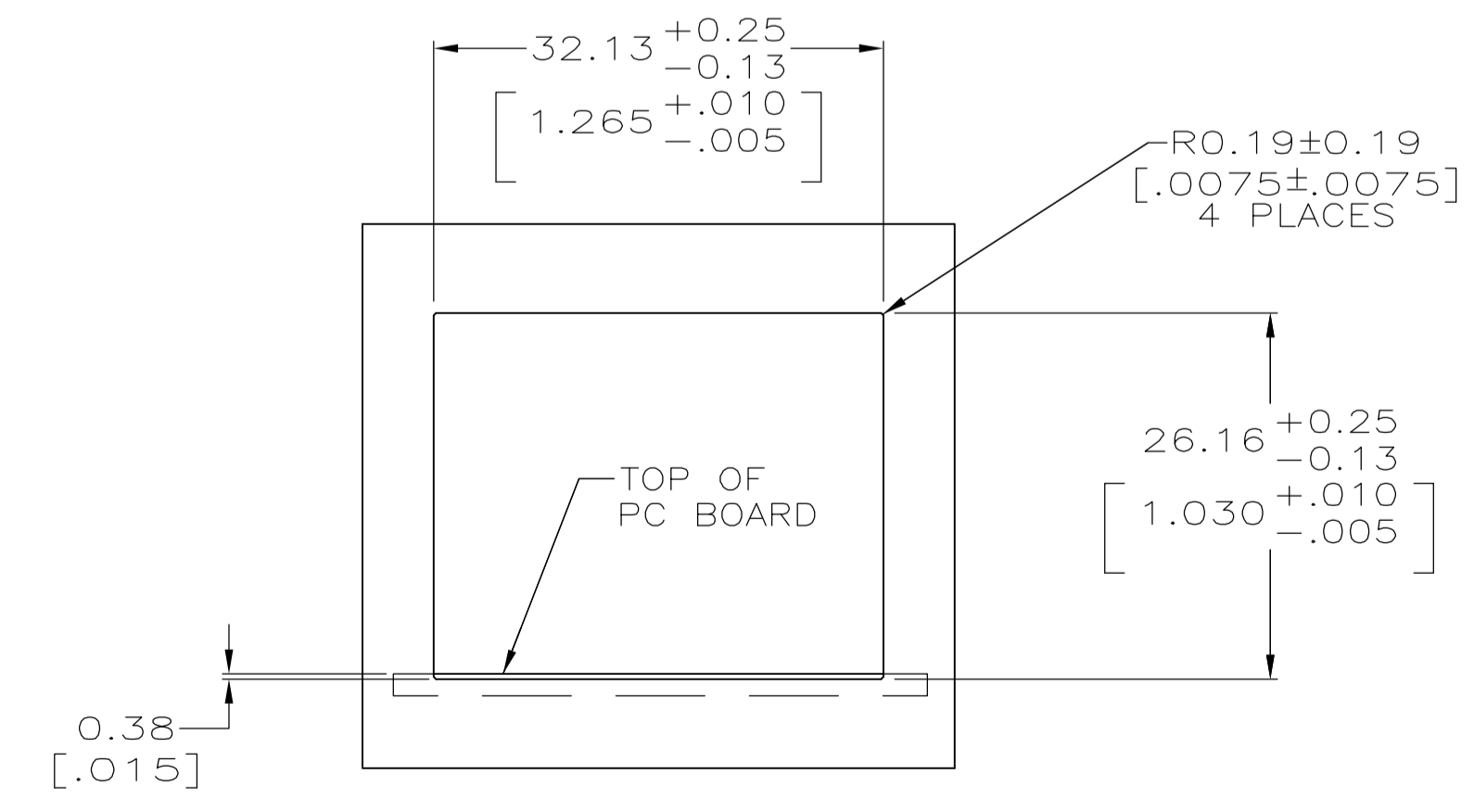
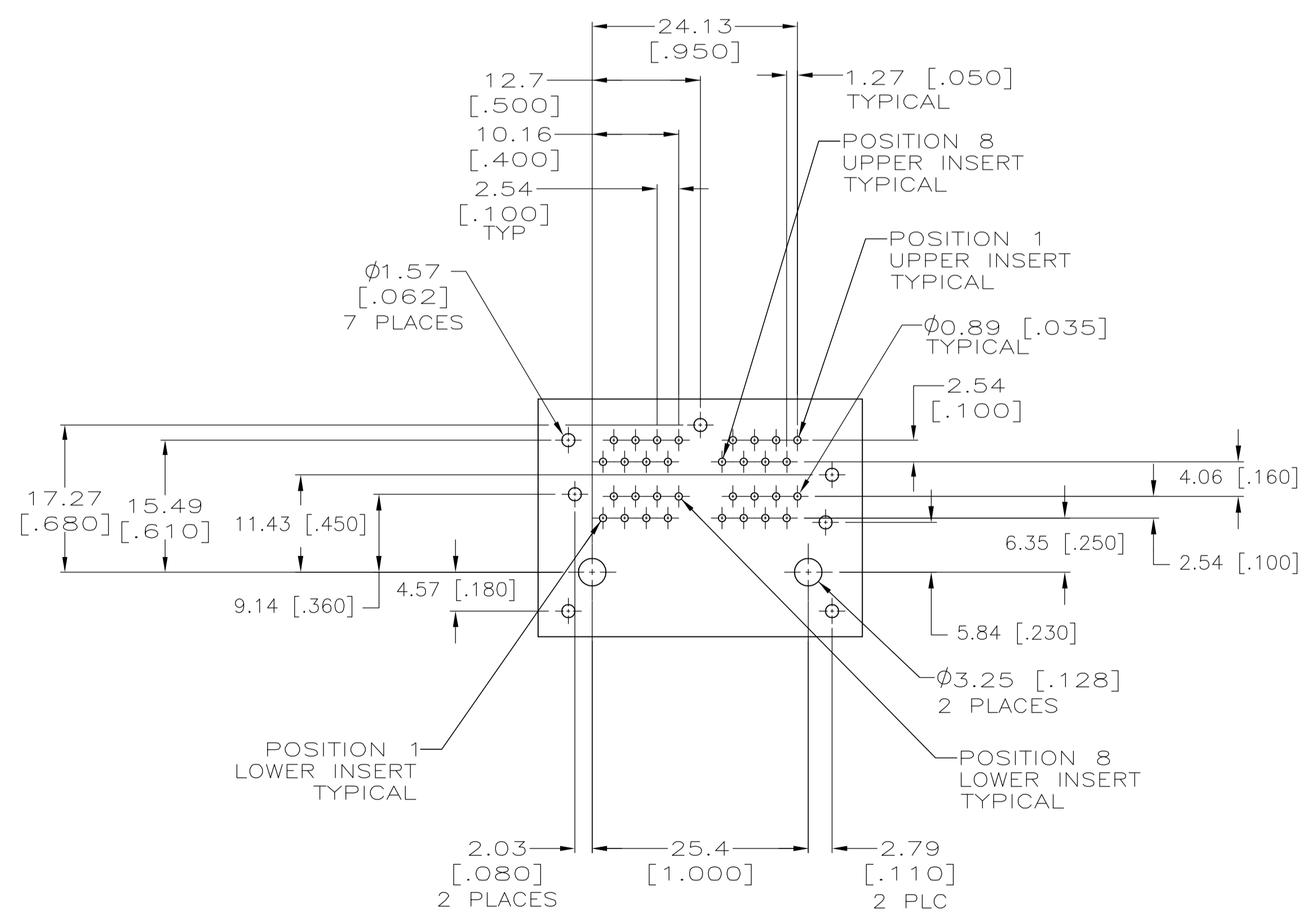
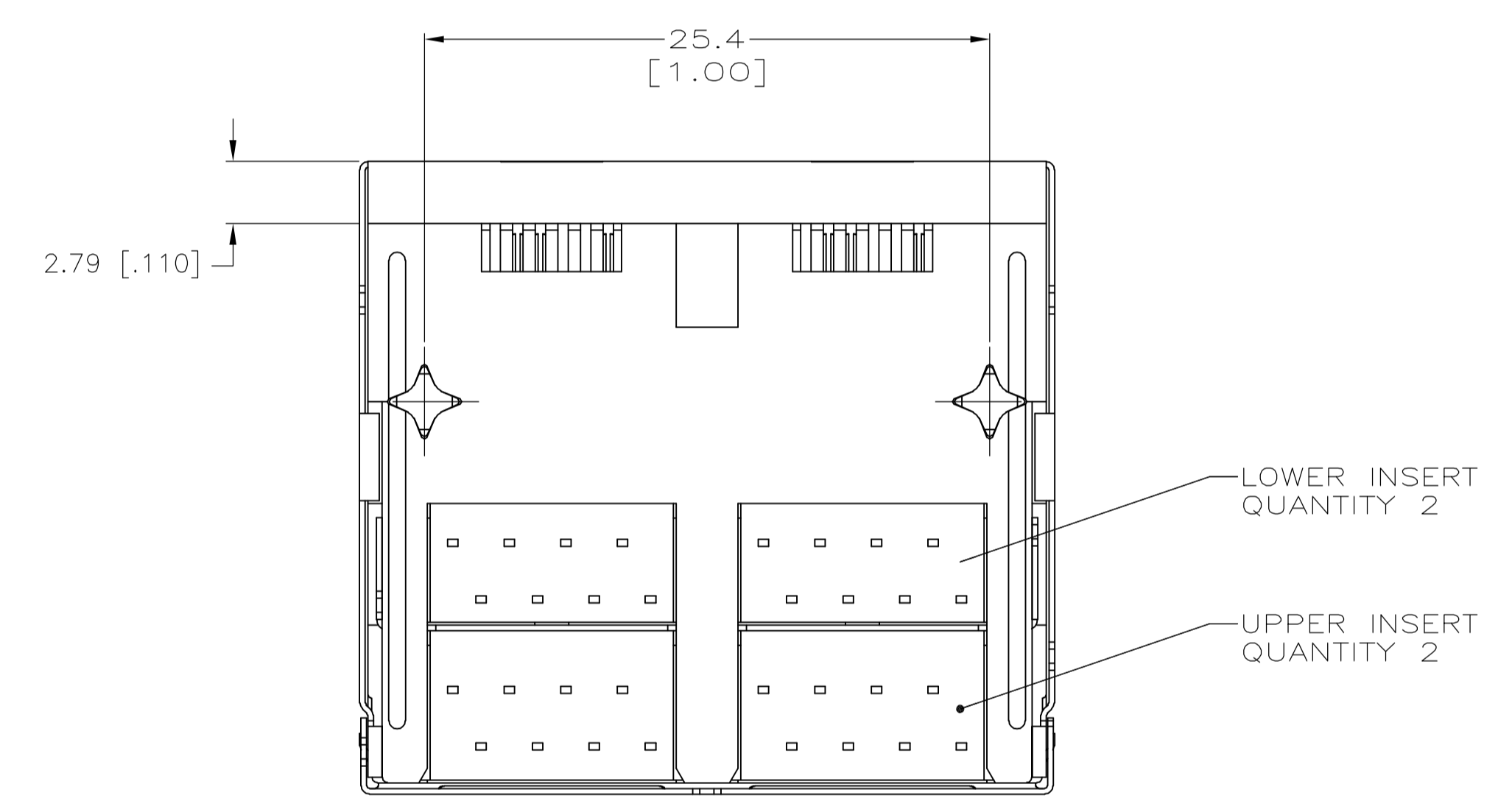
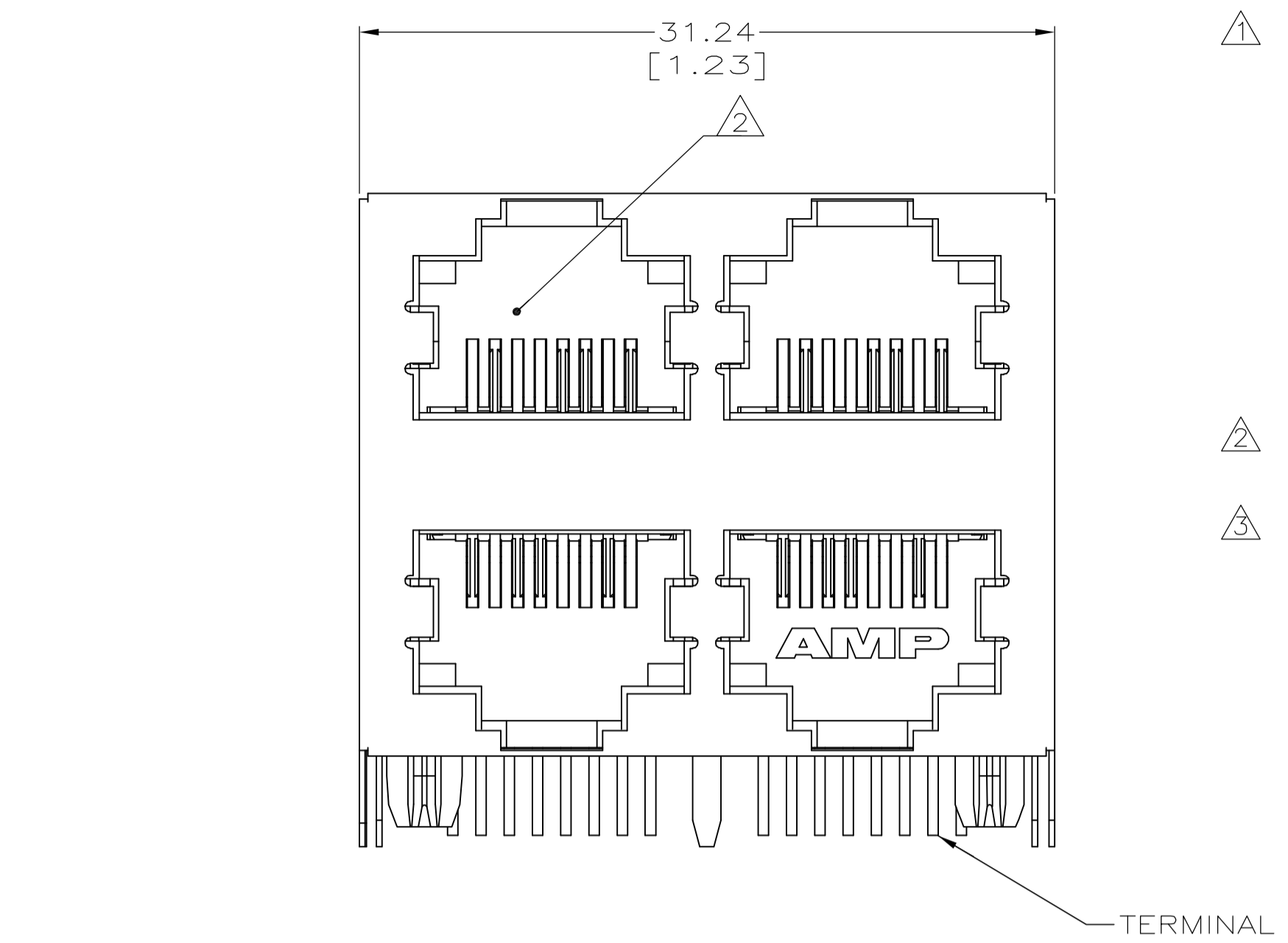
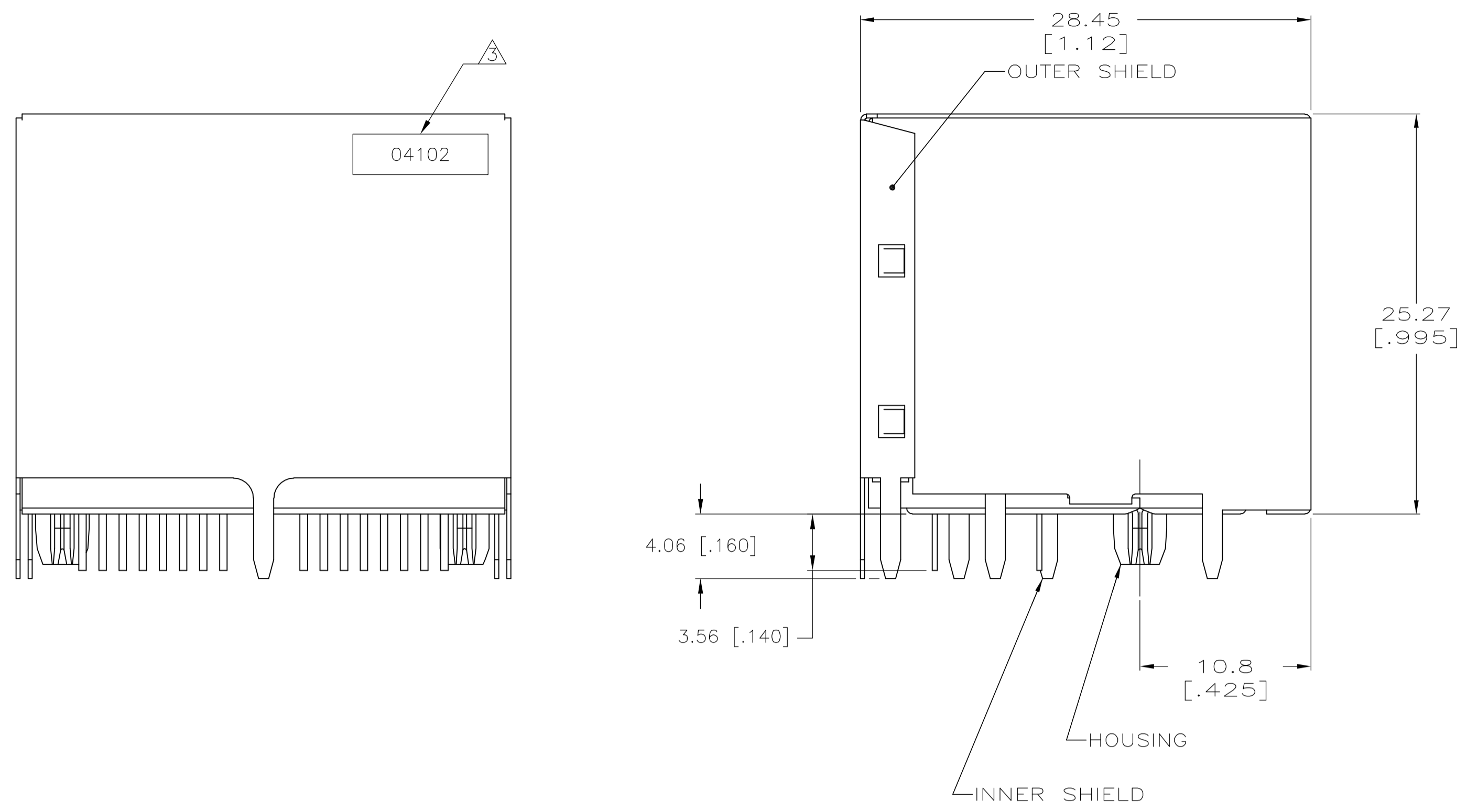

MATERIAL:
 HOUSING - PCT POLYESTER, BLACK, UL94V-0.
 OVERMOLDED TERMINAL ARRAY - PBT, BROWN.
 TERMINALS - 0.33 [.013] THICK PHOS BRONZE
 PLATED WITH 1.27µm [.000050] MIN THICK
 HARD GOLD IN LOCALIZED AREA AND 3.81µm
 [.000150] MIN THICK MATTE TIN IN SOLDER
 AREA OVER 1.27µm [.000050] MIN THICK
 NICKEL UNDERPLATE.
 SHIELD - 0.25 [.010] THICK COPPER ALLOY
 PLATED WITH 2.03µm [.000080] MIN BRIGHT TIN
 OVER 1.27µm [.000050] MIN NICKEL.

**JACK CAVITY CONFORMS TO FCC RULES AND
 REGULATIONS, PART 68 SUBPART F.**

**DATE CODE LOCATED ON REAR OF PART
 APPROXIMATELY AS SHOWN:
 FIRST 2 DIGITS ARE LAST 2 DIGITS OF YEAR,
 SECOND 2 DIGITS ARE MANUFACTURING
 WORK WEEK,
 LAST DIGIT IS DAY OF WEEK, WITH SUNDAY = 1.**